



EXU-S 22

EXU-S 24

EXU-S Technical Data.

Low-lift pallet truck with
driver's stand-on platform



In accordance with VDI guidelines 2198 resp. 3597, this specification applies to the standard model only. Alternative tyres, mast types, ancillary equipment, etc. could result in different values.

					STILL	STILL		
					EXU-S 22 ①	EXU-S 22 ②		
Characteristics	1.1	Manufacturer						
	1.2	Manufacturer's model designation						
		Platform type				Rear access	Side access	
	1.3	Power supply (electric, diesel, petrol, gas, mains electric)				Electric		
	1.4	Type of control (hand, pedestrian, stand-on, rider seated, order picker)				Stand-on		
	1.5	Capacity/load	Q	kg	2200			
	1.6	Nominal load centre	c	mm	600			
	1.8	Load distance	x	mm	1023			
	1.9	Wheelbase	y	mm	1617			
Weight	2.1	Weight (incl. battery)				1120	1120	
	2.2	Axle loadings laden	drive end/load end		kg		1500/1820	1500/1820
	2.3	Axle loadings unladen	drive end/load end		kg		910/210	910/210
Wheels Tyres	3.1	Tyres				Polyurethane		
	3.2	Tyre size	drive end	mm	ø 250 x 100			
	3.3	Tyre size	load end	mm	ø 85 x 80			
	3.4	Castor wheels (size)	drive end	mm	2 x ø 140 x 54			
	3.5	Wheels, number (x = drive wheel)	drive end/load end		1 x -2/4			
	3.6	Track width	drive end	b ₁₀ mm	470			
	3.7	Track width	load end	b ₁₁ mm	388			
Dimensions	4.4	Lift height		h ₃ mm		130		
	4.8	Seat/Platform height		h ₇ mm		200		
	4.9	Height of tiller in drive position	mini/maxi		h ₁₄ mm		1030	
	4.15	Forks height lowered		h ₁₃ mm		85		
	4.19	Overall Length		h mm		2415 ¹⁾	2485 ¹⁾	
	4.20	Length to front face of forks		l ₂ mm		1225 ¹⁾	1295 ¹⁾	
	4.21	Overall width		b ₁ mm		720		
	4.22	Forks dimensions		s/e/l mm		55/172/1190		
	4.25	Forks external width		b ₅ mm		560		
	4.32	Floor clearance, centre of wheelbase		m ₂ mm		30		
4.34	Working aisle width for pallets 800 x 1200 lengthwise (b ₁₂ x l ₆)		A _{st} mm		2615 ¹⁾	2685 ¹⁾		
4.35	Outer turning radius		W _a mm		2238 ¹⁾	2308 ¹⁾		
Performances	5.1	Travelling Speed	laden/unladen	km/h		10/12		
	5.2	Lifting Speed/Time	laden/unladen	m/s/s		3.0/2.1		
	5.3	Lowering Speed/Time	laden/unladen	m/s/s		1.9/2.0		
	5.8	Gradeability	laden/unladen	%		15%		
	5.9	Acceleration time (over 10 m)	laden/unladen	s		6.2/4.6		
	5.10	Service brakes				electromagnetic		
Electric motors	6.1	Drive motor, rating S2 = 60 min		kW		3.0		
	6.2	Lift motor, rating at S3 = 15%		kW		2.2		
	6.3	Battery to DIN 43531/35/36; A, B, C, no				IEC 254-2; B		
	6.4	Battery voltage, capacity Ks		V/Ah		24/450		
	6.5	Battery weight ± 5% (dependant on manufacturer)		kg		410		
	6.6	Energy consumption according to VDI cycle		kWh/h		1.05		
Others	8.1	Drive control				AC-controller		
	8.4	Noise peak at operator's ears		dB (A)		< 65		

1) With battery tray 600 Ah: + 85 mm

Values for turning radius W_a for working aisle width calculation.

Forks length		EXU-S 22						EXU-S 24					
		distance X	PF Rear access		PF Side access		distance X	PF Rear access		PF Side access			
			450 Ah	600 Ah	450 Ah	600 Ah		450 Ah	600 Ah	450 Ah	600 Ah		
990	mm	823	2038	2123	2108	2193	805	2020	2105	2090	2175		
1190	mm	1023	2238	2323	2308	2393	1005	2220	2305	2290	2375		
1600	mm	1433	2648	2733	2718	2803	1415	2630	2715	2700	2785		
2390 ^{a)}	mm	Not available						2205	3420	3505	3490	3575	
2390 ^{b)}	mm	Not available						1847	3062	3147	3132	3217	

a) Wheelbase suitable for picking up 3 Euro pallets CROSSWISE

b) Wheelbase suitable for picking up 2 Euro pallets LENGTHWISE

STILL	STILL
EXU-S 24 ①	EXU-S 24 ②
Rear access	Side access
Electric	
Stand-on	
2400	
600	
1005	
1599	
1120	1120
1500/1840	1500/1840
910/230	910/230
Polyurethane	
ø 250 x 100	
ø 85 x 80	
2 x ø 140 x 54	
1 x -2/4	
470	
388	
130	
200	
1030	
85	
2415 ¹⁾	2485 ¹⁾
1225 ¹⁾	1295 ¹⁾
720	
61/172/1190	
560	
30	
2615 ¹⁾	2685 ¹⁾
2220 ¹⁾	2290 ¹⁾
9/12	
3.0/2.1	
1.9/2.0	
15%	
6.3/4.8	
electromagnetic	
3.0	
2.2	
IEC 254-2; B	
24/450	
410	
1.07	
AC-controller	
< 65	

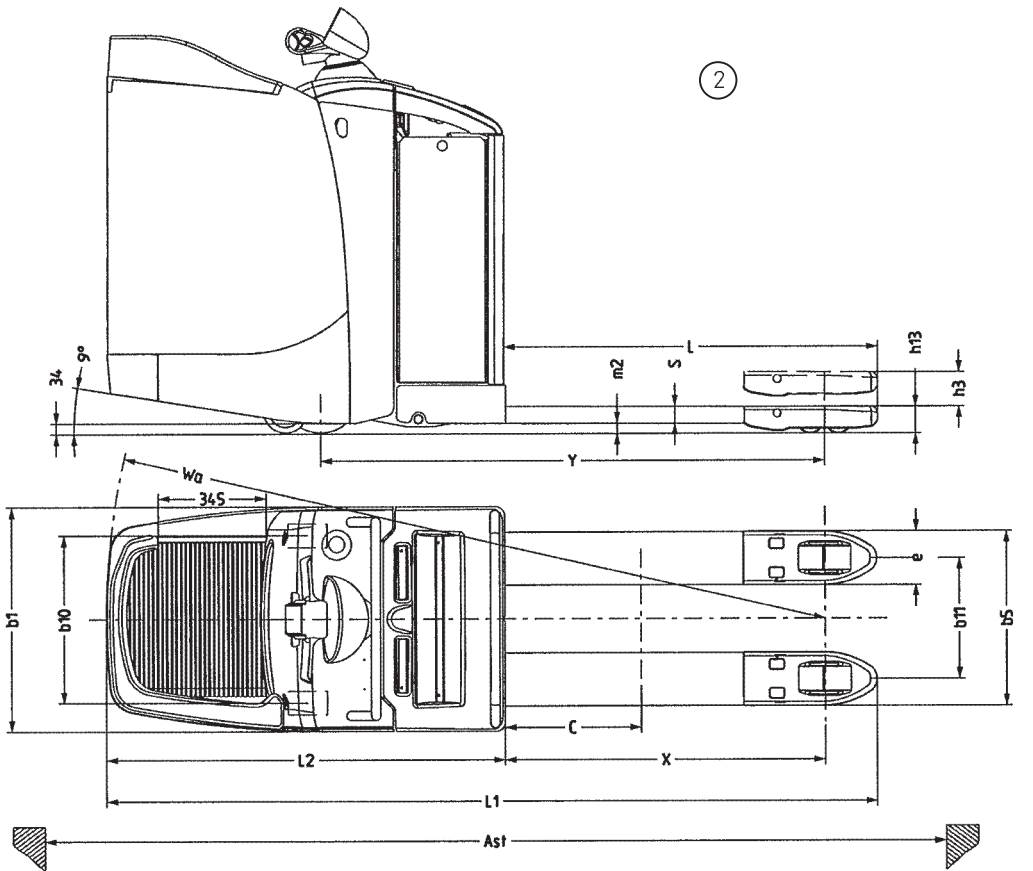
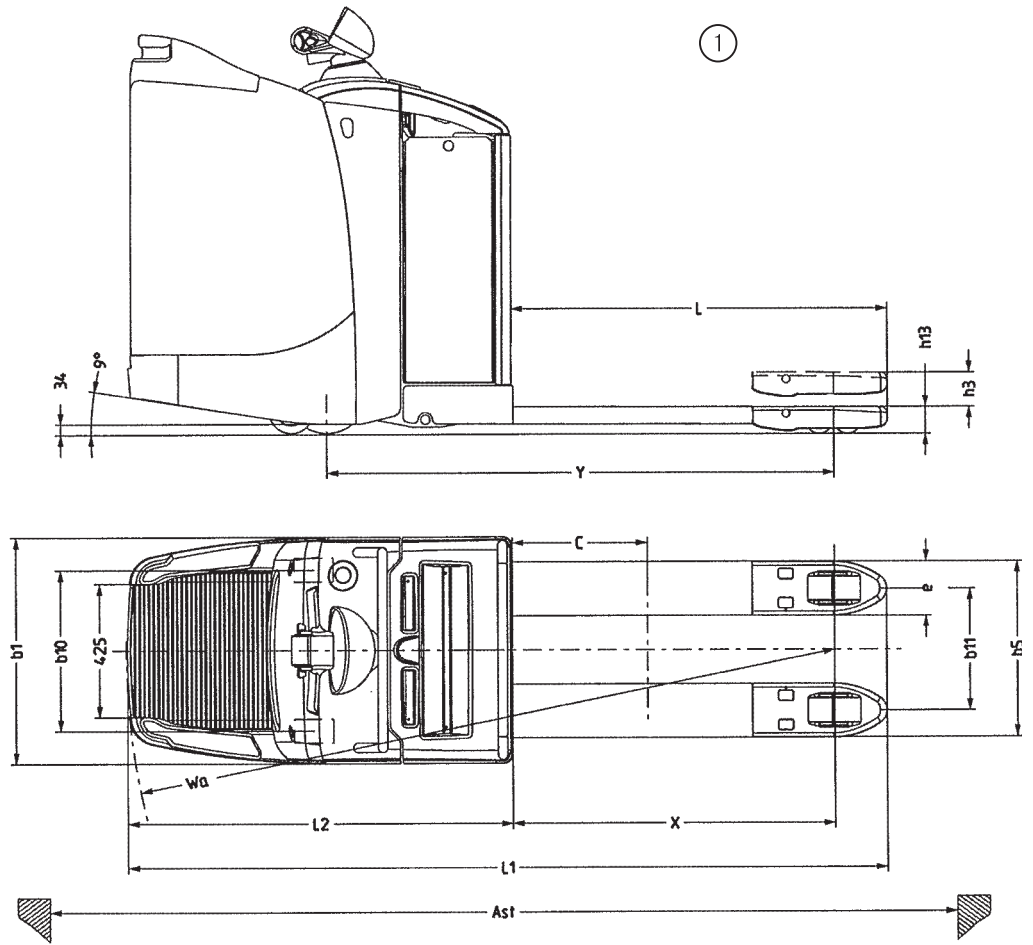

Low-lift pallet truck with driver's stand-on platform.

Chassis frame.

- Optimised for loading and unloading vehicles, the EXU-S's design provides excellent driving characteristics on loading ramps, dock levellers and in the tight confines of lorries, containers and trailers.
- Acting as a slider, the lower edge of the frame will never catch on ramp edges, while the tapered platform sides allow reversing from vehicles without any risk of damage to the trailer side walls or loading dock seals, even when loading the final two pallet rows.
- The platform is an integral part of the frame, utilising a 'D-Box' structure that provides extreme reliability, even on the most violent of dock crossings.
- To optimise traction, the centre mounted drive unit is sprung and features variable wheel pressure proportional to the load on the forks.
- For lateral stability, two huge twin-caster wheels have been specially designed for the EXU-S for extreme reliability in the most arduous applications.

Steering.

- Fully electric "Fly-by-Wire" steering with automatic return to the straight-ahead position.
- In the centre steering range, any unintentional steering movements are electronically damped, to guarantee precise straight ahead driving without unwanted steering movements.
- Automatic speed reduction during cornering combined with the support castors gives high lateral stability and reduces the centrifugal force effects on the operator.

Multi-function controls.

- The new multi-function control "COCKPIT" contains all the functions for access, operation and monitoring on the EXU-S.
- Due to the ergonomic layout of the buttons, all functions can be reached with either hand without changing grip.
- The following functions are integrated in the COCKPIT:
 - Direction and speed control
 - Steering
 - Lifting and lowering
 - Work hour meter
 - Discharge battery indicator
 - Alternative drive profiles
 - Access control (provided as standard through PIN code entry)
 - Diagnosis (by means of service code)
- In addition, the COCKPIT provides a secure support for the operator whilst driving.

Driver's stand-on platform.

- Depending on the application, the EXU-S is available with two platform types that have been ergonomically matched to the driver's needs. These needs are very different from one type of job to another, so there is no need to compromise by having only one platform type.
- For predominantly cross docking applications where pallet transfer or long travel distances require the driver to spend a long time standing on the machine, the platform with side access will offer the greatest comfort and security for driving in both directions.
- If the driver has to step in and out frequently for any peripheral work, (scanning, manual handling, etc.) then the platform with open rear access is best suited.
- Either platform style provides great comfort due to the padded backrest and shaped side supports combined with an innovative, unique, fully sprung platform to protect the driver's legs and back from shocks.
- The machine incorporates various storage facilities and a holder for rolls of stretch wrap integrated within the covers.
- A writing surface with document clip is available as standard on the EXU-S.

Drive.

- Powerful, economical and hence cost saving due to the 3.0 kW AC-drive.
- The latest generation AC-controller combined with the STILL COCKPIT offers the possibility to adapt the truck's performance from one drive mode to another at the touch of a button.
- In "ECO" mode ('Tortoise' button) the drive is controlled to provide low current draw and standard acceleration. This results in 15% more battery economy but the same productivity and pallet throughput as other machines of this type currently available.
- In "BOOST" mode ('Hare' button) the drive is controlled to provide very high torque/acceleration and a higher travel speed with load. While the economy remains unchanged, the productivity increases by around 25% compared to other machines of this type currently available.
- Within each mode, the drive characteristics can be further fine-tuned (speed, acceleration, braking) to precisely match application or driver preferences.
- Thanks to the speed sensor feedback to the controller, the EXU-S will start smoothly and accelerate evenly up to maximum travel speed, independent of the load on forks.
- Truck braking is activated by releasing the COCKPIT drive control switch or by plugging. The AC-motor acts as a generator and recovers energy when braking (regenerative braking).
- When starting on a gradient, or if the drive switch is released or put into neutral, the controller will immediately detect any unintentional movement or roll-back and activate the magnetic disk brake.

Hydraulic system.

- A compact pump and 2.2 kW motor unit with built in oil tank, solenoid valve and maximum pressure valve operates on the lift cylinder with lift cut-out.
- This powerful hydraulic system offers very short lift times, even with full load, thereby providing high productivity for loading and unloading vehicles.

Brake system.

- There are two independent brake systems.
- "Soft" braking with energy recovery, activated by releasing or reversing the drive control.
- "Emergency" braking takes place when the push-button in the COCKPIT is actuated.
- Driving is only possible when the driver is on the stand-on platform, which acts as deadman switch.

Battery.

- The battery is easily accessible, and for two or three shift operation can be changed with a hoist, or from the side using integral roller tracks.
- Two different battery compartment options allow batteries with capacities up to 450 Ah or 600 Ah to be used.

Options.

- Unique modular accessory system using a multi-function frame bar over the battery cover.
- Adjustable A4 writing surface with paper clip.
- Preparation for data terminal.
- Additional mounting system for accessories of all types (on request).
- Load backrest (1200 or 1600 mm height).
- Cold store version (-30°C).
- 600 Ah battery compartment.
- Battery cover made of sheet steel.
- Advanced access control and fleet management with STILL FleetManager.

Safety.

- Trucks are built to the EC Guidelines 98/37 and carry the CE symbol.
- STILL is certified to ISO 9001.

